



INSTALLATION INSTRUCTIONS

Accessory
USB (TYPE-C) ATTACHMENT
P/N 08E71-MKR-D10

Application
CBR1000ST/SP

Publication No.
MII
Issue Date
December 2019

Honda Dealer: Please give a copy of these instructions to your customer.

PARTS LIST

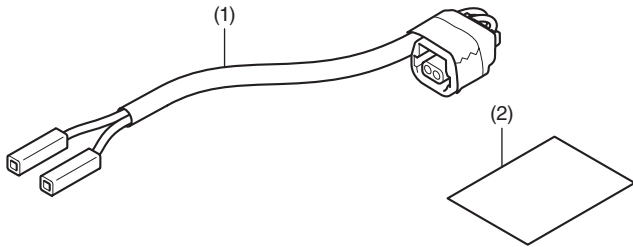

No.	Description	Qty
(1)	USB sub harness	1
(2)	URL paper	1

USB (TYPE-C) Sold separately

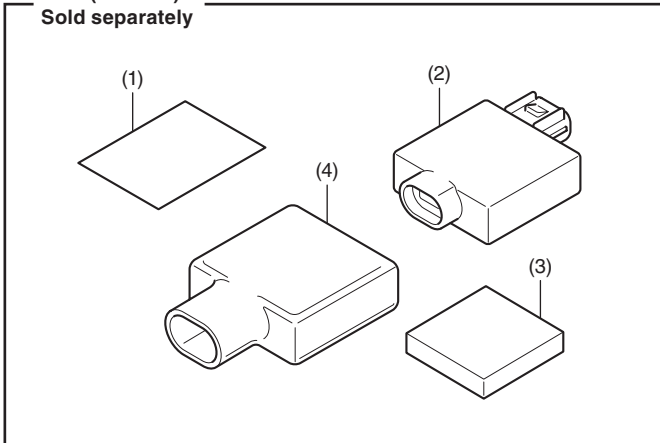

No.	Description	Qty
(1)	URL paper	1
(2)	USB charger unit	1
(3)	Double-sided adhesive tape (30 x 30 mm)	1
(4)	Cover	1

TOOL AND SUPPLIES REQUIRED

Scale
Isopropyl alcohol
Shop towel

TORQUE INFORMATION

Refer to the Service Manual for the torque values of the removed parts.

Please Convey the Following Information to the Customer During Delivery

NOTICE:

- Rated current of all of the USB Attachment that is mounted on the vehicle can be used up to 3A. Use that exceeds the rated current is the cause of fuse blow or dead battery.

INSTALLATION

CAUTION

- To prevent burns, allow the engine, exhaust system, radiator, etc. to cool before installing the accessory.

NOTE:

- Heat the bonding surfaces with a hair dryer if the ambient air temperature is below 21°C (70°F).
- The adhesive reaches full strength in 72 hours. Wait at least 24 hours before riding your motorcycle.
- Take care not to damage the painted surfaces of the motorcycle.
- Disconnect the negative (-) cable from the battery before installing this accessory.
- After reconnecting the battery, refer to the motorcycle Owner's Manual and set the meter.
- After this accessory installation, check the lights (e.g. right/left turn signal lights and brake lights) for proper operation.
- Save all removed parts unless otherwise indicated.

- Illustration shows CBR1000ST type, another type is similar.

- Refer to the Service Manual for the motorcycle, remove the motorcycle parts, and disconnect the negative (-) cable from the battery as shown.

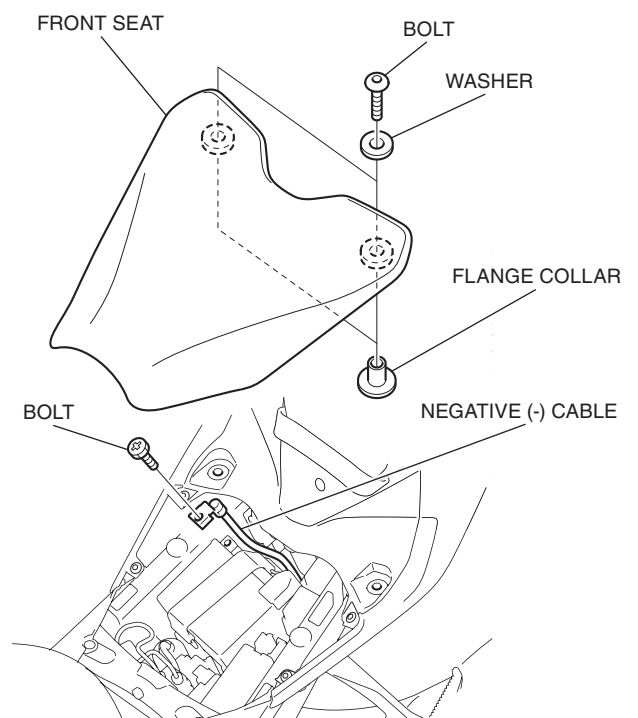

- Refer to the Service Manual for the motorcycle, remove the motorcycle parts.

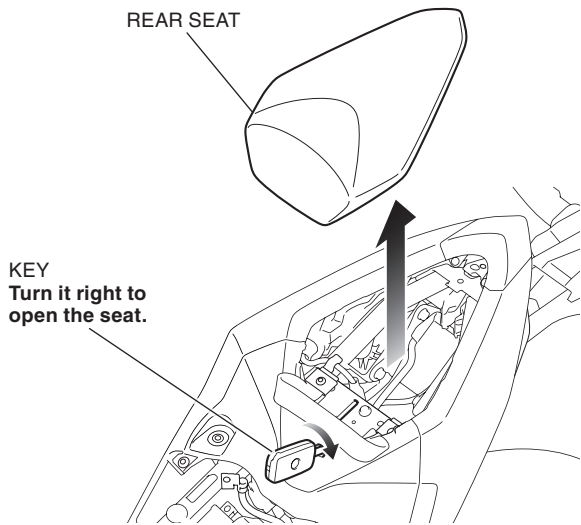

- Connect the USB sub harness as shown.

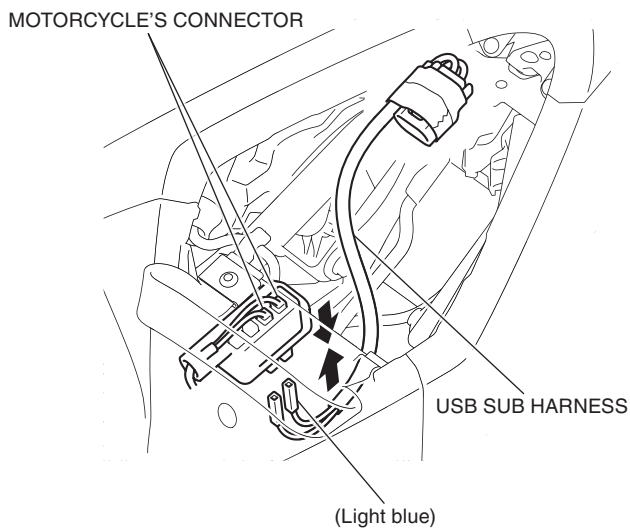

- Install the cover as shown.

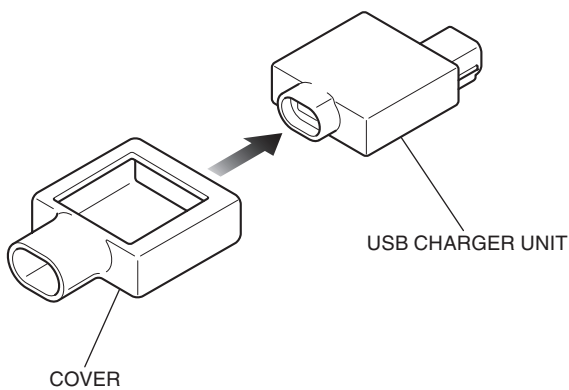

- Attach the double-sided adhesive tape as shown.

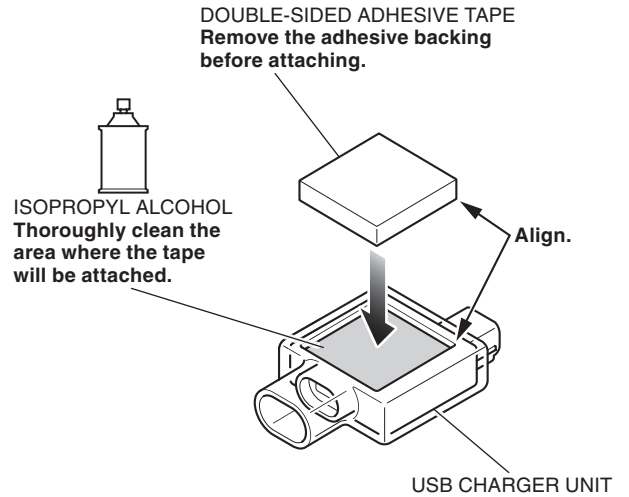

- Install the USB charger unit as shown.

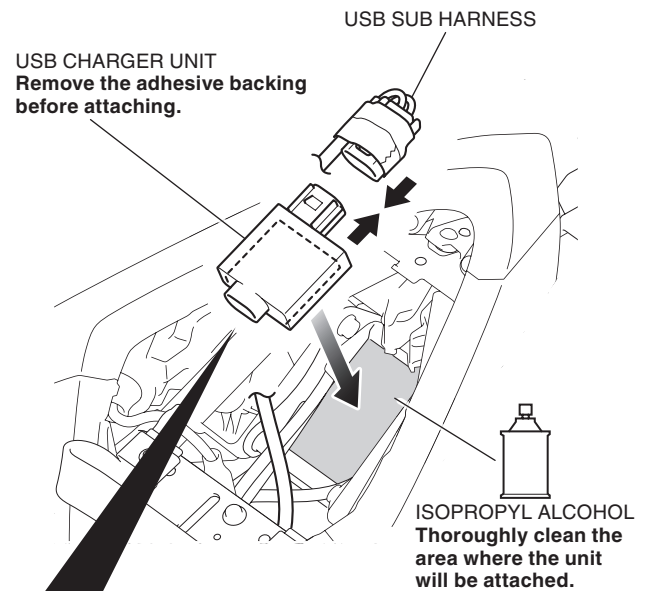

Align the rear fender stepped part and the front side of the USB charger unit. Also, be careful not to interfere the rear side of the USB sub harness with the rear cowl.

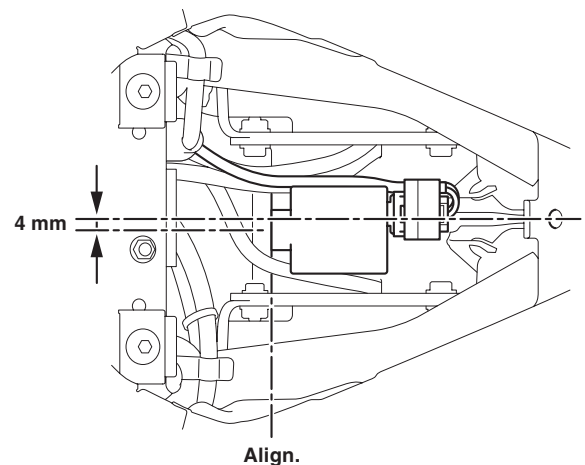

- Install the motorcycle's parts in the reverse order of removal.